

“PA1000” Series Airbag Leveler Submittal

“PA1000” SERIES AIRBAG DOCK LEVELER MODEL SPECIFICATIONS

| MODEL | LIP* | DECK* | NOMINAL LENGTH | WIDTH | HINGE CF1045 | SEAMLESS HINGE TUBE | OPERATING RANGE |
|-----------------------------|------------|-------|----------------|---------|-----------------|---------------------|-----------------|
| PA16630/PA17630 | 1/2" x 16" | 1/4" | 6' | 72"/83" | 1" diameter | 1 5/8" dia. O.D. | +12"-12" |
| PA16830/PA17830 | 1/2" x 16" | 1/4" | 8' | 72"/83" | 1" diameter | 1 5/8" dia. O.D. | +12"-12" |
| PA16635,40,45/PA17635,40,45 | 5/8" x 16" | 1/4" | 6' | 72"/83" | 1 1/8" diameter | 2" dia. O.D. | +12"-12" |
| PA16835,40,45/PA17835,40,45 | 5/8" x 16" | 1/4" | 8' | 72"/83" | 1 1/8" diameter | 2" dia. O.D. | +12"-12" |

INSERT SPECIFIC JOB REQUIREMENTS FROM CHART

| | | | | | | | |
|--|--|--|--|--|--|--|--|
| | | | | | | | |
|--|--|--|--|--|--|--|--|

STANDARD CAPACITY A.N.S.I. CAPACITY

| | |
|--|--|
| | |
|--|--|

*Lip and deck, 55,000 lb. minimum yield steel;
3 year structural warranty.

STANDARD FEATURES

- (2) P4H1012 Bumpers
- Lip 16"
- Grease Fittings
- Full Range Toe Guards
- Powder Coated Yellow
- Maintenance Strut
- Lip Keepers/Night Locks
- Fully Hydraulic Actuation
- Yellow & Black Diagonal Safety Stripe on Toe Guards
- Motor--115 Volt 1ph. 60Hz

OPTIONAL FEATURES

- Lip 18"
 - Lip 20"
 - Weather Seals
 - Foam Insulation
 - Abrasive Deck
 - Laminated Bumper
- _____
Size

| |
|------------|
| JOB |
|------------|

"PA1000" Series Airbag Leveler Pit Detail

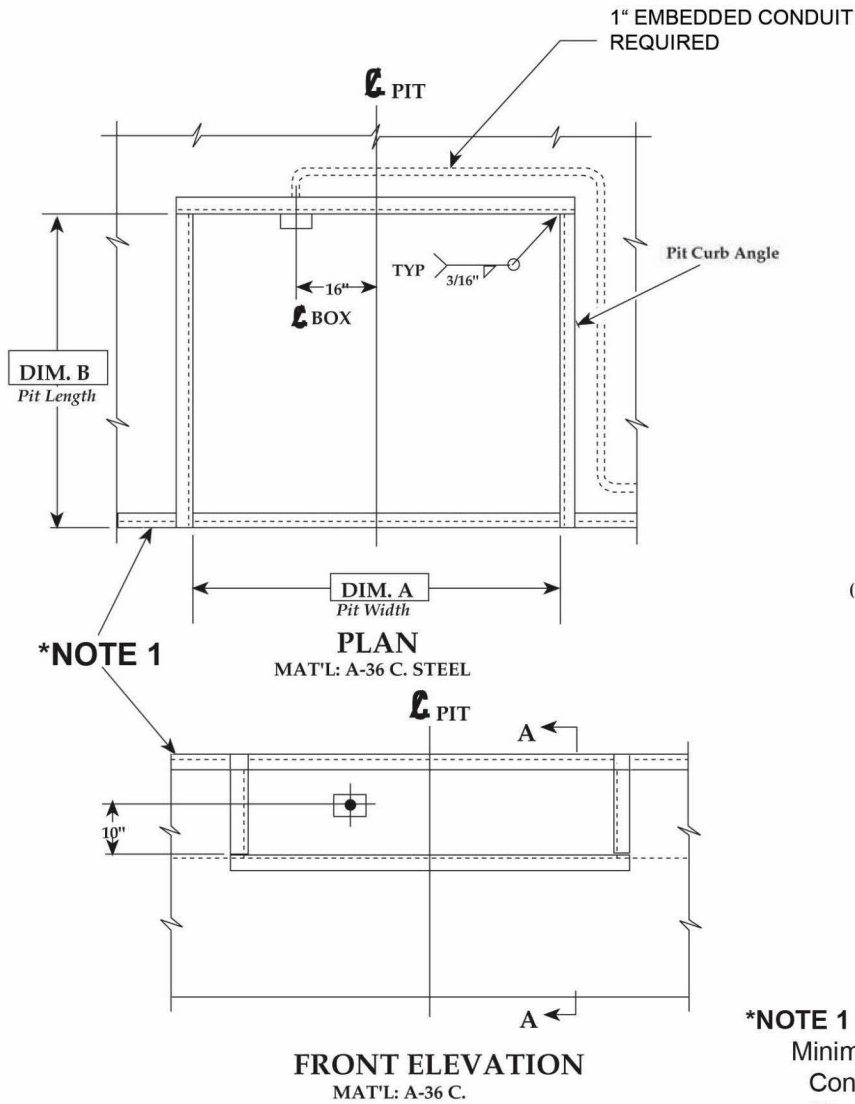

| VARIABLE DIMENSIONS | | | | |
|---------------------|-----|-----|---------|-----|
| MODEL SIZE | "A" | "B" | "C" | "D" |
| 6'W x 6'L | 74" | 63" | 19 1/2" | 20" |
| 6'W x 8'L | 74" | 87" | 19 1/2" | 20" |
| 7'W x 6'L | 85" | 63" | 19 1/2" | 20" |
| 7'W x 8'L | 85" | 87" | 19 1/2" | 20" |

INSERT SPECIFIC JOB DIMENSIONS FROM CHART

| | | | | |
|--|--|--|--|--|
| | | | | |
|--|--|--|--|--|

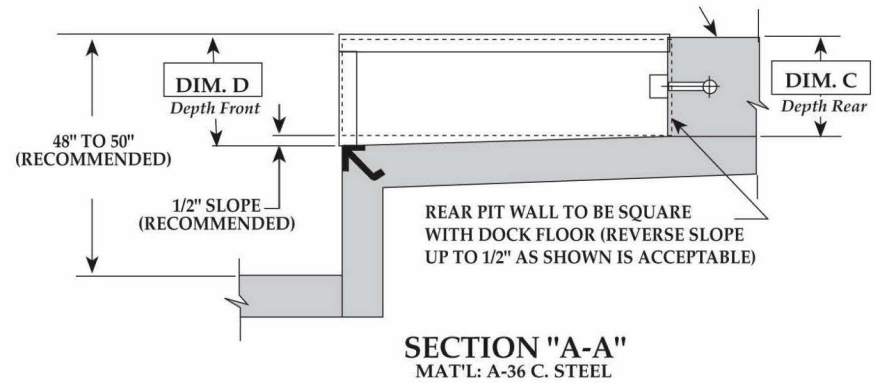

***NOTE 1 :** Angle 3"x3"x1/4"x20"
Minimum Length or Run
Continuous Pit to Pit.
(Supplied By Others)

| | | | |
|-------|-----------------|---------------|-----------------|
| DRAWN | SCALE: AS NOTED | DATE: 1/30/95 | DRAWING NUMBER: |
|-------|-----------------|---------------|-----------------|

| TOLERANCES | | |
|----------------|-------------------|--------|
| Inch Dimension | Decimal Dimension | Angles |
| = | = | = ° 1 |

JOB