



# M Series Mechanical Pit Levelers



*Rugged. Dependable. PIONEER.*

P.O. Box 338 • Spring Hill, Tennessee 37174 • 1-800-251-3382 • fax: 931-486-0316 • [www.pioneerleveler.com](http://www.pioneerleveler.com)



# **WARNING**

**DO NOT install, operate or service product unless you have read and understand the Safety Procedures, Warnings, Installation and Operating instructions contained in this manual. Failure to do so could result in serious injury and/or death.**



## Safety Procedures



**WARNING:** Read and understand all safety practices and operating instructions Before installing, operating or servicing the dock leveler. Failure to follow the safety practices and operating instructions may result in property damage, serious bodily injury and/or death.

**If you do not understand the safety procedures or the instructions, ask your supervisor to explain the safety procedures and/or teach you how to use the dock leveler.**



**CAUTION:** The installer and/or operator **MUST** be very familiar with the operation, function and various parts of the PIONEER Pit Leveler **PRIOR** to installation and/or operation. If this is not the case, it is **IMPERATIVE** that the installer and/or operator read, and fully understand, the entire contents of this manual. **Be certain to read and understand all warning and caution statements contained in this manual prior to any installation, operation or servicing of this unit.**

- 1 Do not operate this equipment while under the influence of drugs or alcohol.
- 2 Do not stand in the driveway between the dock leveler and a truck backing or pulling away.
- 3 Be sure the truck wheels are chocked, or the truck is held in place by a restraining device, before attempting to load or unload the truck.
- 4 Do not use the dock leveler if it looks broken or does not seem to work right. Lockout/tag out the defective equipment. Tell your supervisor immediately.
- 5 Do not operate the leveler with equipment, material or people on the platform and/or lip or in front of the leveler.
- 6 Be certain that equipment, material or people are not on the dock leveler before allowing a truck to pull out.
- 7 Keep clear of the dock leveler when it is moving. Never place your hands, arms, feet, or legs in the position where a moving dock leveler or a moving load could cause injury. **If in doubt, do not do it!**
- 8 If the dock leveler is not working properly, using the operation instructions in this manual, **do not use the dock leveler.** Contact your authorized PIONEER representative.
- 9 Never attempt to work under the dock leveler, for service or repair, without proper placement of maintenance strut.
- 10 Damage to the dock leveler, personal injury or death can result from abuse and/or negligent use of this equipment.
- 11 If you have any questions, or if a malfunction occurs which is not understood, ask your supervisor to contact your authorized PIONEER representative for assistance **PRIOR** to attempting any corrective measures.





***THIS IS THE SAFETY ALERT SYMBOL. IT IS USED TO ALERT YOU TO POTENTIAL PERSONAL INJURY HAZARDS. OBEY ALL SAFETY MESSAGES THAT FOLLOW THIS SYMBOL TO AVOID POSSIBLE INJURY AND/OR DEATH.***



## **WARNING**

***INDICATES A POTENTIALLY HAZARDOUS SITUATION WHICH, IF NOT AVOIDED, COULD RESULT IN SERIOUS INJURY AND/OR DEATH.***



***KEEP THIS MANUAL AND ALL SAFETY PROCEDURES IN A SECURE LOCATION WITH EASY ACCESS.***



***WARNING! READ AND UNDERSTAND THIS ENTIRE MANUAL PRIOR TO OPERATING.***



***WARNING! A DOCK LEVELER CAN BE A POTENTIAL THREAT TO PERSONS AND PROPERTY, IF NOT USED PROPERLY. SAFE OPERATION IS THE RESPONSIBILITY OF THE OPERATOR.***



***WARNING! DO NOT ENTER THE AREA IN FRONT OF OR BELOW THE DOCK LEVELER. SERIOUS PERSONAL INJURY AND/OR DEATH MAY RESULT.***



***WARNING! DO NOT ATTEMPT TO INSTALL, MAKE REPAIRS OR ADJUSTMENTS. ONLY A TRAINED AND AUTHORIZED SERVICE TECHNICIAN SHOULD PERFORM REPAIRS OR ADJUSTMENTS. ONLY A QUALIFIED CONTRACTOR/SUB-CONTRACTOR SHOULD PERFORM THE INSTALLATION PROCESS. CONTACT YOUR LOCAL PIONEER DEALER FOR ASSISTANCE.***

## SECTION 1

## INSTALLATION INSTRUCTIONS RECEIVING AND HANDLING

RECEIVING:



Before installing the dock leveler, read and follow the safety procedures and the operating instructions. Failure to follow the safety procedures could result in serious injury and/or death.

Check for possible damage or missing parts immediately upon receipt of unit. Note any damage on receiving papers.

Prepare any claims against carrier if necessary.

**NOTE: Damage noticed after receipt must be reported to carrier within 15 days.**

Notify PIONEER of any damage or missing parts.

HANDLING:

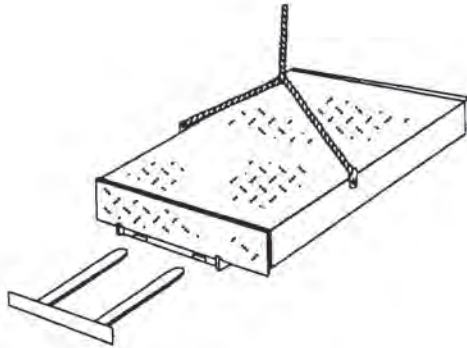

FIGURE A

Move leveler into position by using:

- chain sling inserted into upper side plate holes. (See Figure A)
- Fork lift, inserted into front fork slots;
- Fork lift, inserted into rear fork slots just below the deck.

NOTE:

Two bumpers, and weather seals, if applicable, are strapped under leveler. Handle with care to avoid damage to these components.

Contact PIONEER for chain sling assembly (Part #1700)

## SECTION 1

## INSTALLATION INSTRUCTIONS INSTALLATION

INSTALLATION: (Consists of 3 phases)

Pit preparation

Leveler Preparation

Leveler Installation



**Caution: Before installing the leveler, use proper safety signs and barriers to separate the work area from the remainder of the dock.**



Never allow anyone to stand on or near dock leveler when it is being lifted or placed into the pit. Failure to follow this warning can allow the dock leveler to fall, tip, or swing into people, resulting in serious injury and/or death.



# "M" Series Pit Detail

FIGURE B – PLAN VIEW

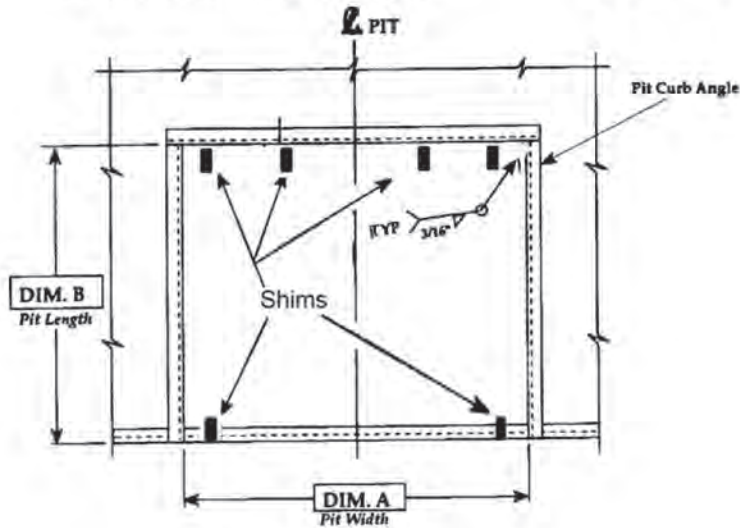

PLAN  
DIM. "B" MAT'L: A-36 C. STEEL

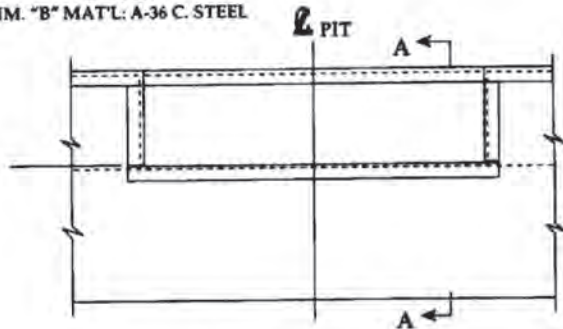

FRONT ELEVATION  
DIM. "B" MAT'L: A-36 C. STEEL

VARIABLE DIMENSIONS				
MODEL SIZE	"A"	"B"	"C"	"D"
6'W x 6'L	74"	63"	19 1/2"	20"
6'W x 8'L	74"	87"	19 1/2"	20"
6'-6" W x 6'L	80"	63"	19 1/2"	20"
6'-6" x 8'L	80"	87"	19 1/2"	20"
7'W x 6'L	85"	63"	19 1/2"	20"
7'W x 8'L	85"	87"	19 1/2"	20"
6'W x 10'L	74"	111"	19 1/2"	20"
6'-6" W x 10'L	80"	111"	19 1/2"	20"
7'W x 10'L	85"	111"	19 1/2"	20"

INSERT SPECIFIC JOB DIMENSIONS FROM CHART

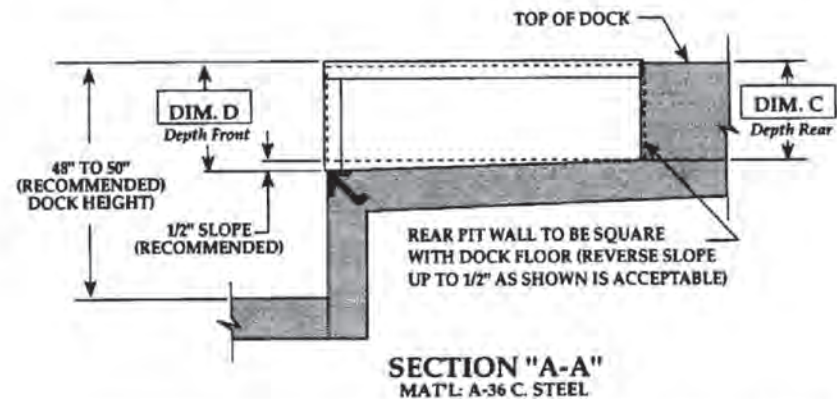

SECTION "A-A"  
MAT'L: A-36 C. STEEL



PO Box 338 \* Spring Hill, TN 37174  
931/486-2296 \* 800/251-3382 \* Fax: 931/486-0316  
www.pioneerleveler.com

NOTES

JOB

DRAWN: D.E.A.	SCALE: AS NOTED	DATE: 6/19/96	DRAWING NUMBER PMI-2010
------------------	--------------------	------------------	----------------------------

TOLERANCES		
Inch Dimension =	Decimal Dimension =	Angles =
1/16"	.005	1°

## SECTION 1

## INSTALLATION INSTRUCTIONS PIT PREPARATION

### PIT PREPARATION

1. Examine pit.
2. Measure pit dimensions. (See "Variable Dimensions" Figure B, Page 2)



Before welding the rear frame, cover the rear weather seal with a sheet of steel to prevent setting fire to the weather seals. Failure to do so may result in property damage.

**Pit walls should be square and plumb. Clean all debris from pit. Verify that walls are square and plumb and that the floor is level in the back and on the sides of the pit.**

### PRE-PLACEMENT OF SHIMS:

1. Place shims in correct locations on pit floor before lowering leveler into place in pit.

Proper shim thickness will insure that deck of leveler is level with dock floor.

NOTE 1: Shims are to be placed directly under each rear frame upright, under lip keepers, and under snubber spring tab. Weld shims to base assembly and front curb steel. (See Figure C, Page 3) and (See Plan View, Page 2).

NOTE 2: For units with a 20" lip the lip keepers are separate. Prior to shimming, weld the angle with the lip keeper under the front base frame. (See Figure C, Page 3) (See Figure E, Page 6)

## SECTION 1

## INSTALLATION INSTRUCTIONS LEVELER PREPARATION

### LEVELER PREPARATION

1. Position leveler directly in front of pit
2. Cut restraining band on lip.

Remove band completely from leveler..

FIGURE C

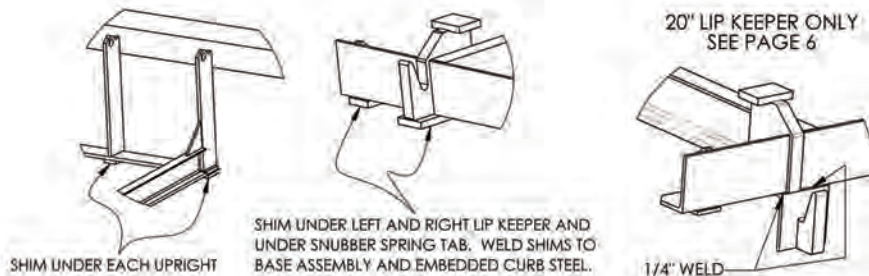
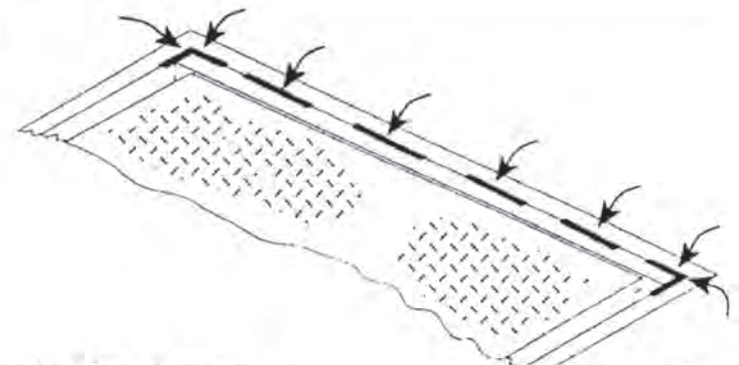

FIGURE D





**! WARNING**

Keep fingers, hands, and head away from the lip, rear of deck plate, and upright angle. Fingers, hands, or head could be struck by or caught between the lip and other parts of the dock leveler causing serious injury and/or death,

**! WARNING**

Improper installation of anchoring devices or installation into aged or unsound concrete could result in serious injury and/or death.

**! WARNING**

DO NOT work under the dock leveler, ramp, or lip unless the maintenance strut is in place.

**LEVELER INSTALLATION:**

1. Place leveler into pit opening.

Allow one inch (1") equal clearance between leveler sides and pit walls. Rear frame angle of leveler should be tight against and flush with rear curb angle for proper welding.

2. **CUT RESTRAINING BAND.**

Recheck shim packs to ensure leveler is at proper height, flush with floor level, front and rear.

For leveler with a 20" lip - with leveler flush with dock floor locate lip keepers on frame / embedded curb angle and move upwards until lip touches bottom of keeper. Lip keeper should be located under safety stops.

Shims must be placed properly under each rear frame upright, and front lip keepers. (See Figure C, Page 3, for close up view and Plan View B, Page 2, for shim locations.)

Skip weld rear of leveler to curb angle (weld center first then ends) and front shims to leveler and curb angle. (See Figure D, Page 3 & Figure C, Page 3)

3. Bring deck section of leveler to fully raised position.

To operate, pull **and hold** the ratchet release chain located at rear of leveler.

4. Place maintenance strut securely under leveler.

Place strut in tubes located on base & under lip. Lower leveler until strut is held in place by tubes on each end.



**SECTION 1****INSTALLATION INSTRUCTIONS  
LEVELER INSTALLATION**

## LEVELER INSTALLATION:

5. Weld all shims securely in place.	Rear shim pack must be welded to the base frame. Front shims must be welded securely to frame and steel curb angle.
6. Store maintenance strut.	Walk forward onto leveler, returning it to dock level with lip in keepers.
7. Install bumpers on dock face.	Securely bolt and/or weld bumpers to dock face as close to pit opening as possible. Bumpers should be flush with dock floor or 48" off ground. Raised bumpers should be supported to floor from behind.
8. Complete weld at rear of leveler.	Weld to cover approximately 50% of the length of the rear angle. Ensure welds are placed directly behind frame uprights and at ends of angle. (See Figure D, Page 3)



**CAUTION:** Before you start to install the leveler, use proper safety signs and barriers to separate the work area from the remainder of the dock.

## SECTION 1

## INSTALLATION INSTRUCTIONS LEVELER PREPARATION

### 20" LIP KEEPER INSTALLATION INSTRUCTIONS

Two separate lip keeper angles are provided with every unit that has a 20" lip. These angles are tack welded to the leveler base frame just behind the lip.

Break each one loose and set the leveler into the pit per the installation instructions in the owner's manual.

Prior to angle installation or shimming make sure that the unit is snug against the embedded curb angle at the back of the pit.

Place the lip keepers under the front base angle on either side of the unit with the top of the angle protruding out past the base 1/4" in the front and on the left for the left hand keeper and on the right for the right hand keeper. This will facilitate welding.

Fully weld the keeper angle to the base angle.

Proceed with shimming per the owner's manual.

### FIGURE E

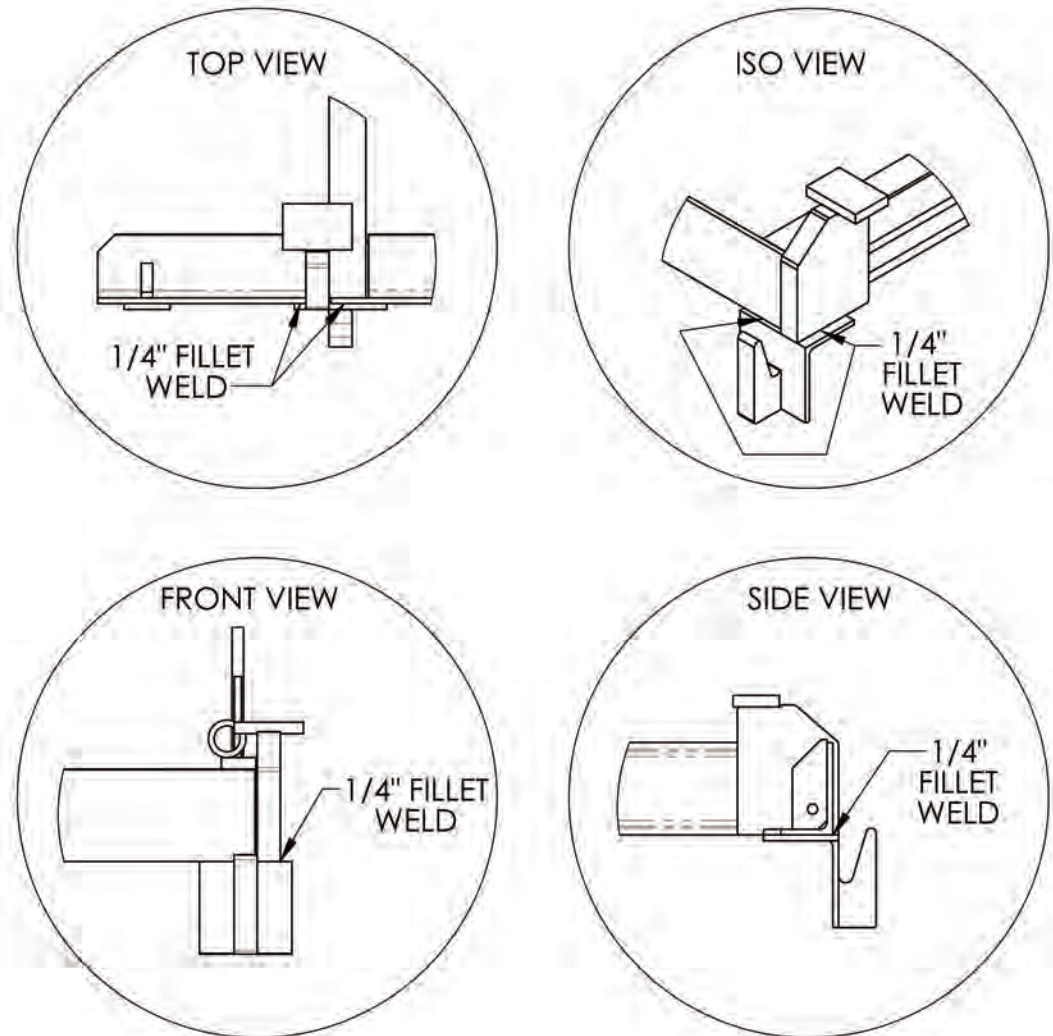



## SECTION 2

## OPERATING INSTRUCTIONS ABOVE DOCK OPERATION

### WARNING

ALWAYS secure the vehicle with a vehicle restraint or wheel chocks before operating the dock leveler.

- \* DO NOT operate leveler with anyone standing on or in front of leveler.
- \* DO NOT lift the leveler by hand.
- \* ALWAYS keep fingers, hands, feet, and head clear of all moving parts.

### WARNING

If the lip does not fully extend, do not lift by hand. Restore leveler to dock level and try again. If lip still does not fully extend, the dock leveler requires maintenance or adjustment. Notify your supervisor. DO NOT use the leveler until it has been repaired. Failure to do so could result in serious injury and/or death.

### WARNING

If the lip does not fall to the stored position, the dock leveler requires maintenance or adjustment. Notify your supervisor. DO NOT use dock leveler until it has been repaired. Failure to do so could result in serious injury and/or death.

#### ABOVE DOCK USE:

1. Pull firmly **and hold** the release ring located in rear of deck.

When deck raises and lip extends, release the ring. DO NOT release the ring until the lip is fully extended.

2. Walk forward onto deck to lower unit onto truck bed. (Truck should be secured firmly against bumpers with "Truck Restraint" or wheel chocks.)

The lip will slowly begin to close. Once lip makes firm contact with truck bed, it will fully extend again.

3. When truck departs, lip will close to pendant (not stored) position.

This action applies when truck is above dock height.

4. Walk forward onto deck until unit is returned to stored position.

In this position, lip is secure in lip keepers, and ready to receive the next truck.

**SECTION 2****OPERATING INSTRUCTIONS  
ABOVE DOCK OPERATION****ABOVE DOCK USE:**

5. Leveler may be recycled with truck at dock.

Pull the rear release ring in short, rapid pulls allowing deck to raise 10" – 15" above dock with lip in the closed position.

Walk forward onto leveler, returning it to dock level with lip in keepers.

This allows operator to close the truck and/or building door prior to truck departure.



## SECTION 2

## OPERATING INSTRUCTIONS BELOW DOCK OPERATION

### BELOW DOCK USE: (WITH LIP EXTENDED)

- |  |  |
|--|--|
| 1. Repeat steps 1 & 2 for above dock use.  |  |
| 2. As you walk forward on the leveler, pull <b>and hold</b> the safety leg release ring located in the front of the deck plate (toward the lip). | This will pull safety legs away from the pads they would normally contact allowing unit to go below dock.<br><br>When lip makes firm contact with the truck bed, release the front ring. |
| 3. When truck departs, lip will return to pendant (not stored) position.   | Lip will be in front of lip keepers, and deck will remain below floor level.   |
| 4. To recycle unit after truck departure, pull release ring in short, rapid pulls.   | This action will allow the deck to raise 2" – 3" above dock floor while the lip remains in a pendant position.   |
| 5. Leveler may be recycled with <b>truck at dock</b> .   | Follow Step #4 to recycle.   |
| 6. Following Step #4, walk forward onto deck until unit is returned to stored position.  | Lip should be completely closed and resting in lip keepers which provide overnight security.   |

## SECTION 2

## OPERATING INSTRUCTIONS BELOW DOCK OPERATION

### BELOW DOCK USE: (LIP RETRACTED FOR END LOADS)

BELOW DOCK CONTROL OPTION IS RECOMMENDED FOR THIS OPERATION:

1. Pull release ring in short rapid pulls.

Allow deck to raise 2" – 3" above dock floor. (This will raise lip out of lip keepers, without extending lip.)

2. As you walk forward on the leveler, pull the safety leg release ring located in the front of deck plate.

With Below Dock Control option, lip will be pushed out in front of keepers while safety legs are being pulled away from pads.

3. When truck departs, lip will slowly close to pendant (not stored) position.

Lip will be in front of keepers, and deck will remain below dock.

4. To recycle unit after truck departs, pull release ring in short, rapid pulls.

Continue this until unit is 2" – 3" above dock floor.

5. Leveler may be recycled with truck at dock.

Follow Step #4 to recycle.

6. Following Step #4, walk forward onto deck until unit is returned to stored position.

Lip should be completely closed and resting in lip keepers which also provide overnight security.



**CAUTION: ALWAYS SECURE LEVELER WITH LIP IN KEEPERS AND SAFETY LEGS FORWARD TO INSURE SAFE CROSS TRAFFIC USE.**



**CAUTION:**

Contact your PIONEER representative or the factory if a malfunction occurs which is not understood. DO NOT attempt to correct the situation without proper information and understanding, as this may damage components and void the warranty.

 **WARNING**

BEFORE SERVICING THE DOCK LEVELER, READ AND FOLLOW ALL SAFETY PROCEDURES IN THIS MANUAL. FAILURE TO DO SO COULD RESULT IN SERIOUS INJURY AND/OR DEATH.

 **WARNING**

BEFORE SERVICING THE DOCK LEVELER, ALWAYS POSITION TRAFFIC CONES OR A BARRICADE BEHIND THE DOCK LEVELER. ALSO POSITION CONES OR BARRICADES IN FRONT OF THE LEVELER TO WARN AGAINST VEHICLE TRAFFIC.

- \* ALWAYS NOTIFY A FOREMAN OR SUPERVISOR THAT YOU ARE WORKING UNDER THE EQUIPMENT.
- \* ALWAYS MAKE SURE THAT THE MAINTENANCE STRUT IS IN POSITION BEFORE WORKING UNDER THE LEVELER.
- \* ALWAYS MAKE SURE THAT THE OVERHEAD DOOR IS SECURELY HELD IN THE RAISED POSITION.

**SERVICE AND MAINTENANCE**

PIONEER recommends periodic inspection and servicing of the “M” Series mechanical leveler to assure proper operation and maximum life span of the dock leveler. Units should be inspected a minimum of every six months and if needed, (See “OPERATING INSTRUCTIONS”, Page 7), can be adjusted and lubricated. Contact your local PIONEER dealer to secure a complete maintenance plan.

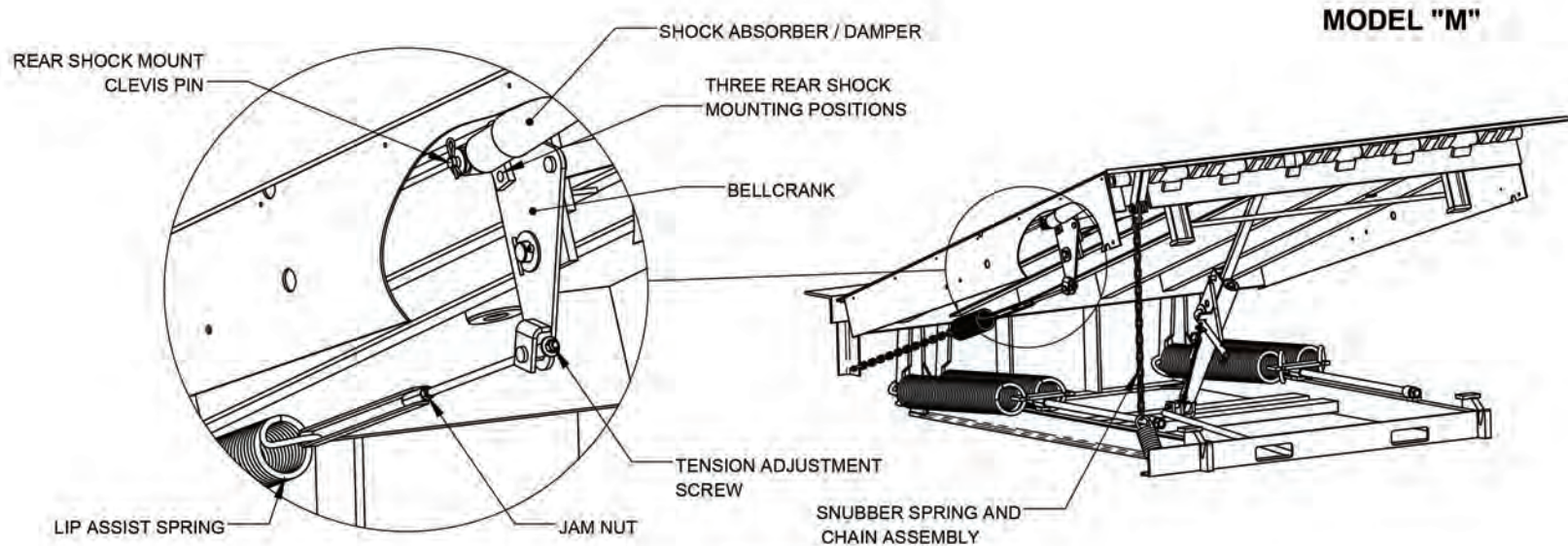

FIGURE F

**LIP ASSIST ADJUSTMENT**

1. Fully raise the leveler and extend the lip. Make sure the leveler is fully raised with very little or no slack in the snubber spring and chain assembly (See FIGURE F).
2. If the lip begins to fall, increase lip assist spring tension. To do so, loosen the jam nut and turn the tension adjusting screw 3 turns clockwise. Retest and repeat if necessary. Retighten the jam nut.
3. Pull the leveler down 8 to 10 inches. The lip should slowly start to close.
4. If the lip does not begin to close, decrease lip assist spring tension by loosening the jam nut, turning the tension adjusting screw 3 turns counter-clockwise. Retest and repeat if necessary. Retighten the jam nut.
5. After the lip assist spring has been properly adjusted, walk the leveler down to dock level. The lip should close fully within 15 to 30 seconds.

**HYDRA-LIP SHOCK ADJUSTMENT**

The "M" model Hydra-Lip, lip extension system utilizes a shock absorber / damper that controls closing speed of the lip plate. It can be adjusted by moving the rear shock mounting pin to different mount hole positions.

1. If the lip plate is falling too quickly, move the rear shock mount clevis pin to the mounting hole that is farthest from the pivot point of the bellcrank.
2. If the lip plate is falling too slowly, move the rear shock mount clevis pin to the hole position that is closest to the bellcrank pivot point.



**NOTE: ALL "M" SERIES LEVELERS ARE TESTED AND ADJUSTED AT THE FACTORY. HOWEVER, MINOR ADJUSTMENTS TO THE MAIN SPRINGS MAY BE REQUIRED ONCE THE UNIT IS INSTALLED, (UNITS WITH WEATHER SEALS NORMALLY REQUIRE MAIN SPRING ADJUSTMENT TO INSURE PROPER LIP EXTENSION). SPRING ADJUSTMENTS ARE CONSIDERED NORMAL MAINTENANCE AND ARE NOT COVERED UNDER WARRANTY.**

The Hydra-Lip operation is designed to keep the lip plate extended until the operator walks forward onto the deck and the leveler begins to lower. No adjustment should be required. (Figure F, Page 12)

 **WARNING**

Read and follow the safety procedures in this manual before doing any service or repair to the dock leveler. ALWAYS SECURE LEVELER WITH MAINTENANCE STRUT BEFORE CLIMBING INTO THE DOCK LEVELER PIT OR DOING ANY MAINTENANCE OR REPAIR UNDER THE DOCK LEVELER. Failure to do so could result in serious injury and/or death.

SYMPTOM:	PROBABLE CAUSE:	CORRECTION:
When release ring is pulled, deck raises but lip does not fully extend	1. Improper main spring adjustment.	Tighten both main spring adjustment nuts one or two rotations clockwise and re-test. Item #22 Page 15 (1 1/2" socket or wrench)
	2. Leveler may be servicing trucks that are above the factory set service range (8' models +12", 6' models +8") causing lip to impact truck during upward movement.	Minor adjustments to service range above dock may be made in the field. Consult the local PIONEER representative or call the factory for assistance.
Lip opens fully when deck raises but immediately begins to close.	1. Lip assist spring is under tensioned.	Loosen jam nut (Figure F, Page 12) on the lip assist tension adjustment screw. Increase the tension by turning the adjustment screw three (3) rotations clockwise and re-test. Re-tighten jam nut.

**SECTION 3****TROUBLESHOOTING**

<b>SYMPTOM:</b>	<b>PROBABLE CAUSE:</b>	<b>CORRECTION:</b>
Lip will not close completely when truck departs.	Lip assist spring is over tensioned.	Loosen jam nut (Figure F, Page 12) on the lip assist tension adjustment screw - Reduce the tension by turning the adjustment screw three (3) rotations <u>counter-clockwise</u> and re-test. Re-tighten jam nut.
Lip closes too quickly as operator is walking the leveler down to operating position.	1. Hydra-lip shock position adjustment is needed.	Move the rear shock mount clevis pin to the mounting hole <u>farthest</u> from the bell crank pivot. (Figure F, Page 12).
	2. Shock is failing after years of use.	Replace with new shock. Item #8, Page 15 (Covered by one (1) year warranty)
Lip closes too slowly as operator is walking the leveler down to operating position.	Hydra-lip shock position adjustment is needed.	Move the rear shock mount clevis pin to the mounting hole that is <u>closest</u> to the bell crank pivot. (Figure F, Page 12).



PARTS LIST	
ITEM	DESCRIPTION
1	LIP PLATE ASSEMBLY
2	HINGE PIN, LIP
3	MAIN SPRING
4	RATCHET MOUNTING TAB, UPPER
5	SAFETY LEG AND MOUNTING ASSEMBLY
6	SAFETY LEG CHAIN ASSEMBLY
7	ROLL PIN
8	SHOCK ABSORBER
9	BELLCRANK ASSEMBLY
10	LIP ASSIST SPRING
11	LIP ASSIST TENSION ADJUSTMENT ASSEMBLY
12	CHAIN SHACKLE
13	SHOCK MOUNT HARDWARE ASSEMBLY
14	LIP ASSIST CHAIN
15	LIP EXTENSION ARM ASSEMBLY
16	UPPER RATCHET PIN KIT
17	CRANK PIVOT ASSEMBLY
18	LIP EXTENSION TAB ASSEMBLY

OPTIONAL KITS (AVAILABLE FOR FIELD INSTALLATION)	
	FULL RANGE TOE GUARDS (SET)
	WEATHER SEAL KIT

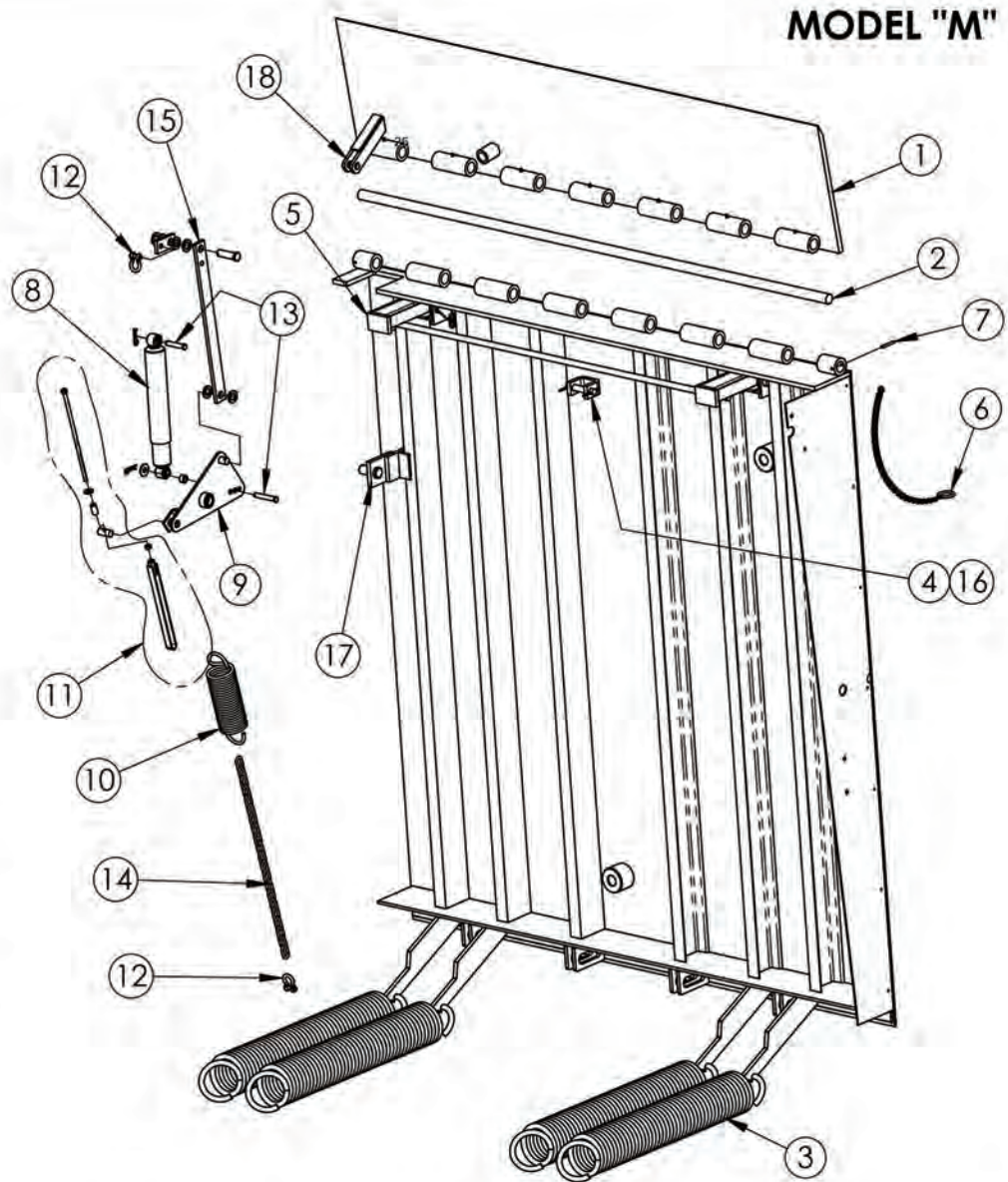

**MODEL "M"**

**PARTS LIST**

ITEM	DESCRIPTION
20	DECK REAR HINGE KIT (SET)
21	SNUBBER SPRING & CHAIN ASSEMBLY
22	MAIN SPRING ADJUSTING ROD ASSEMBLY
23	WING NUT ASSEMBLY
24	WASHER, 1" LOCK
25	RATCHET MOUNTING ASSEMBLY, LOWER
26	RATCHET PULL CHAIN ASSEMBLY
27	RATCHET ASSEMBLY
28	LOWER PIN KIT

**MODEL "M"**

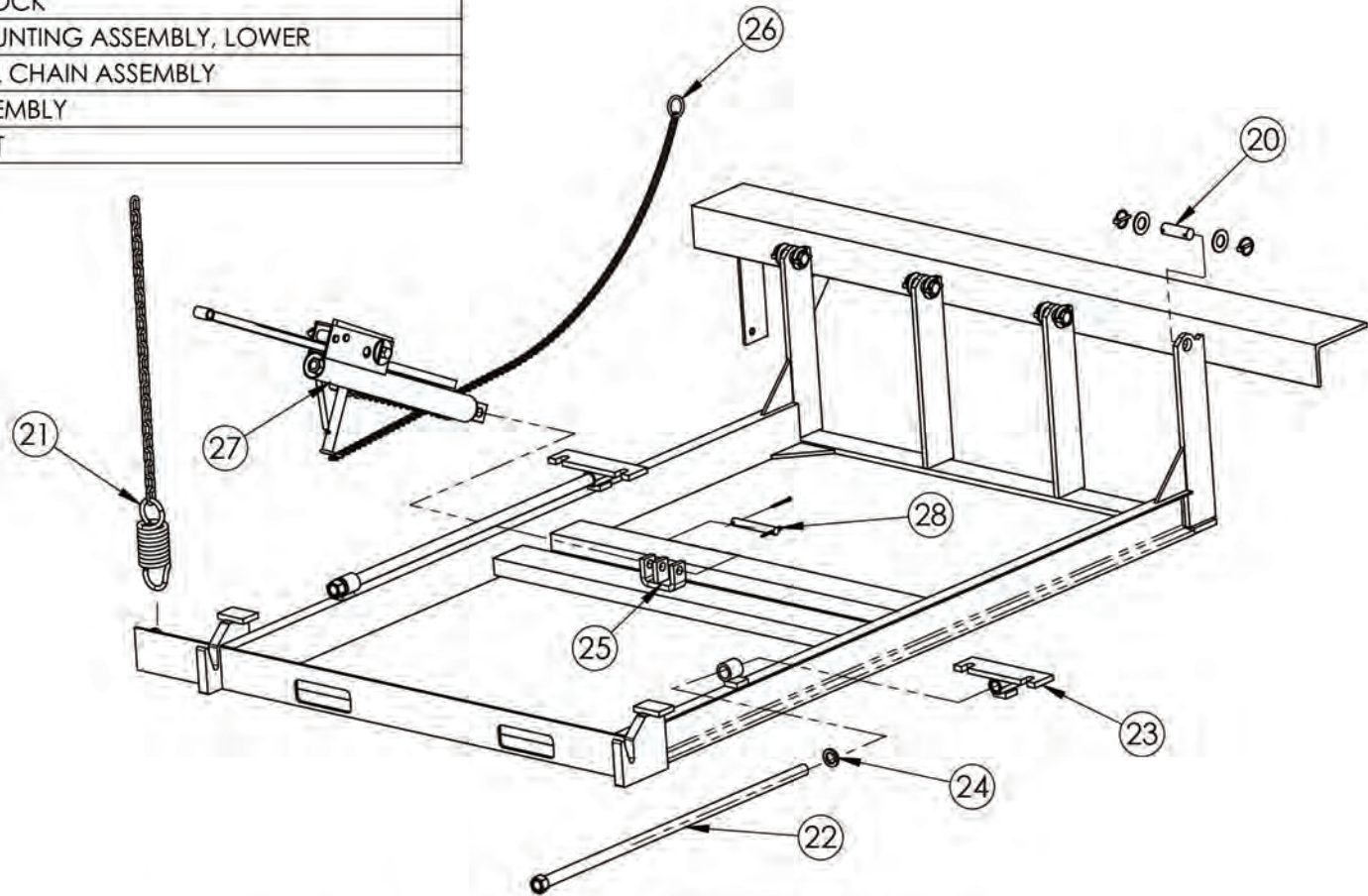





## Warranty Procedure

**The information on the Warranty Claim Request Form must be provided with all warranty claims.**

When a call is received with a warranty problem a Customer Service number (CSF #####) will be issued for that problem only and cannot be used again without prior approval. This number must be on all invoices submitted for payment and on all correspondence.

Before and after pictures of all the work performed must be supplied with each claim. If you take digital pictures, email them to [connerth@pioneerleveler.com](mailto:connerth@pioneerleveler.com). If you use a film camera forward the film to Pioneer Dock Equipment PO Box 338 Spring Hill TN 37174, Attn: Warranty Dept.

No claim will be considered for processing without the required information.

If warranty work is approved, Pioneer's warranty policy for labor requires a formal invoice from the company performing the warranty. Pioneer must receive the labor invoice within 30 days of warranty authorization. Once the invoice is approved by Pioneer, a check will be processed and mailed to the company performing the work.

### **Replacement Part under Warranty**

Any replacement parts will be invoiced and a credit will be given with the damaged parts are returned to Pioneer. Pioneer will determine the only exception, if the parts are not to be returned. A copy of the credit memo will be sent to your billing address. If a check payment is required, the request must be in writing. The request then has to be approved by Pioneer's accounts payable department.

Replacement parts will be sent at Pioneer's discretion either UPS ground or OTR truck. Any other request for shipments will be charged to the dealer. I.e. UPS next day- FedEx etc.

All returned parts will be issued a Return Goods Authorization Number (RGA #####). A form will be faxed to you with this number, the signed copy is to be faxed to 1-931-486-0316 or returned with the parts. The Return Authorization is only good for 30 days. **The RGA # must be listed on all returns, using the RGA form as the packing list.**

No credits will be issued without proper authorization. **No Credit will be given on non-Pioneer parts.**

A copy of the credit memo will be sent to your billing address. The credit will be given against the invoice issued for the replacement parts.

Any questions regarding Warranty or Return Authorization should be directed to Customer Service at [connerth@pioneerleveler.com](mailto:connerth@pioneerleveler.com) or 1-866-728-6195.





# Warranty claim request form

The Following Information Must Be Supplied To Process Any Claim

Dealer Name: \* \_\_\_\_\_

Contact Person: \* \_\_\_\_\_

Pioneer Invoice Number : \_\_\_\_\_ Date Of Purchase: \_\_\_\_\_

End User Name And address:

Name: \_\_\_\_\_

Address: \_\_\_\_\_

City: \_\_\_\_\_ State: \_\_\_\_\_ Zip: \_\_\_\_\_

Product: \_\_\_\_\_

Model Number: \* \_\_\_\_\_ Serial Number: \* \_\_\_\_\_

Customer Complaint: \*

\_\_\_\_\_

Scope of Service Performed: \*

\_\_\_\_\_

\_\_\_\_\_

Estimated Repair: Hours: \* \_\_\_\_\_ \$ \* \_\_\_\_\_

If multiple repairs list hours and \$ for each item.

Pioneer requires an invoice for all claims requiring a payment.

**\*Before And After Pictures Must Be Supplied With All Work Performed**

Purchase a disposable camera and send it to Pioneer along with the receipt.

**\*Required to process all warranty claims.**



## **WARRANTY**

**PIONEER Manufacturing, Inc. guarantees its "M" Series dock levelers to be free from defects in materials and workmanship for a period of five (5) years on structural assembly and one (1) year (365 days) on main springs and miscellaneous parts from date of shipment.**

**A claim for breach of warranty will be honored if the product has been properly installed, maintained and operated within its rated capacity, and not damaged by abuse. Warranty does not cover damage by freight companies. Notify carrier within 15 days of receipt of merchandise and file a claim for hidden damage.**

**PIONEER reserves the right to either repair or replace any defective parts, and will accept full responsibility for the cost of, materials and freight for such repairs. PIONEER'S STANDARD WARRANTY PROCEDURES MUST BE FOLLOWED.**

**PIONEER MANUFACTURING, INC. SHALL NOT BE LIABLE FOR LOSS OF USE OF ANY EQUIPMENT OR INCIDENTAL DAMAGES.**

**PIONEER EXPRESSLY DISCLAIMS ANY AND ALL IMPLIED WARRANTIES.**

**All PIONEER products meet or exceed Federal Occupational Safety and Health Act Standards, Commercial Standards 202-56, and American Society of Mechanical Engineers Specifications ANSI MH14.1-84.**

**Warranty Phone: 1-866-728-6195**

Pioneer reserves the right to make product improvement at any time without prior notice.