

Hydraulic "Top of Dock" Submittal Drawing

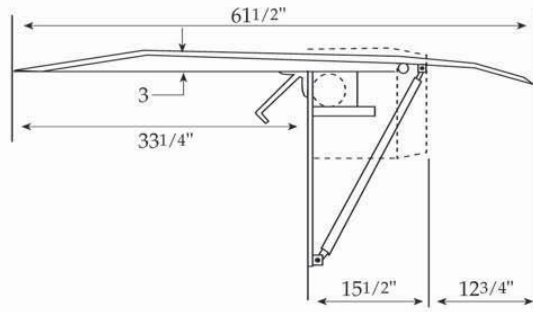

- A = 72"
- B = 15"
- C = 28 1/4"
- D = 17"
- E = 37 1/2"

- OPTIONAL EQUIPMENT**
- 18" Vertical bump blocks for low dock heights
 - Single Phase, 230V
 - 3 Phase Motor
 - 230 Volt
 - 460 Volt
 - 4" Underframe*
 - 6" Underframe*

*Underframe to be used on exceptionally low dock

NOTES:
 Bolt-On Installation Requires
 20 Anchors 5/8" x 5" Minimum

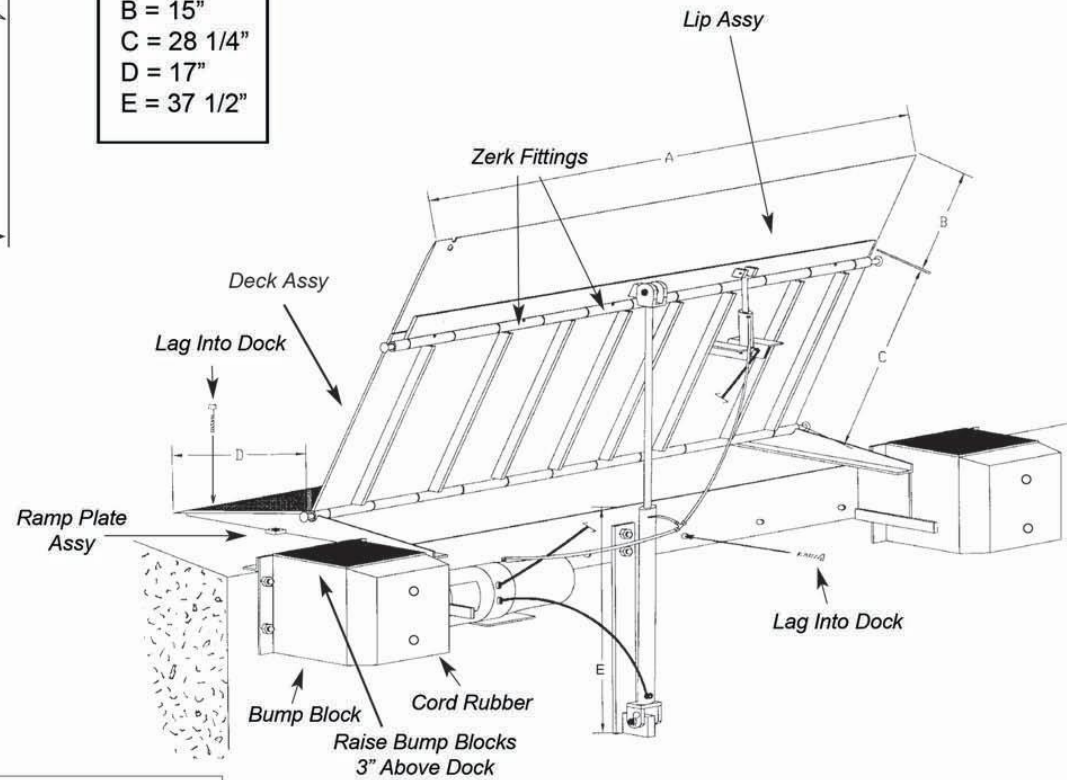

MODEL	CAPACITY
<input type="checkbox"/> HTD72	20,000 lbs.
<input type="checkbox"/> HTD72H	25,000 lbs.

Rotary Products Inc.

202 East High St. PO Box 370 Ashley Ohio, 43003
 Phone #: 1-800-457-5251 Fax #: 740-747-2188



JOB

Rotary Products Inc.

202 East High St. PO Box 370 Ashley Ohio, 43003
Phone #: 1-800-457-5251 Fax #: 740-747-2188



Hydraulic Top of Dock Model No. HTD72 Installation Instructions

1. Remove all existing bumper materials and obstructions from dock edge and sweep clean.
2. Place unit at desired location on dock surface with base plate of unit tight against dock face. Remove shipping bands from hydraulic cylinder and mounting bracket. Place bracket on anchor bolts and tighten nuts in place. (Do not attach cylinder).
3. Anchoring: Use 13/16" holes in leveler as guides for drilling holes in concrete. Use 5/8" x 5" (min.) anchors.
 1. Extend lip forward and support safely with timber brace or other secure means.
 2. Drill and anchor two outside holes in base plate and draw unit tight to dock.
 3. Proceed to rear of unit and anchor all six bolts.
 4. Next, anchor side brackets.
 5. Complete anchoring base plate either by continuous welding to dock edge steel, or bolting all six holes.
 6. Set bump blocks in place on each side of unit and secure by welding to dock edge steel and bolting to dock if steel is less than 6" channel or angle. Anchors at rear must be welded to deck plate, cut off, and ground down to no more than 1/4" above deck surface. Tack weld all hex nuts to leveler and bumpers.
4. Install Cylinder (hose entrance at bottom) on lower mounting tab then connect to lip tab. Lock clevis in place with keys. Connect free end of hydraulic hose to pump fitting. Check fluid level to insure reservoir is full replace plug cap with vent cap supplied with unit.
5. Connect electrical according to prevailing codes. Standard motor: 1 h - 1ph - can be wired for 110 or 220 volts.
6. Check operation to insure unit works correctly. Unit should raise and lip will extend and lock in position. When unit settles to floor of trailer lip lock will disengage. Unit may be recycled with truck in place by raising unit until lip edge clears the rear of trailer then releasing switch.