

"EHP" Series Hydraulic Leveler Submittal

"EHP" SERIES HYDRAULIC DOCK LEVELER MODEL SPECIFICATIONS

MODEL	LIP*	DECK*	NOMINAL LENGTH	WIDTH	HINGE CF1045	SEAMLESS HINGE TUBE	OPERATING RANGE
EHP6625,30/EHP7625,30	1/2" x 16"	1/4"	6'	72"/83"	1" diameter	1 5/8" dia. O.D.	+12"-12"
EHP6825,30/EHP7825,30	1/2" x 16"	1/4"	8'	72"/83"	1" diameter	1 5/8" dia. O.D.	+12"-12"
EHP6635,40,45	5/8" x 16"	1/4"	6'	72"	1 1/8" diameter	2" dia. O.D.	+12"-12"
EHP7635,40,45	5/8" x 16"	1/4"	6'	83"	1 1/8" diameter	2" dia. O.D.	+12"-12"
EHP6835,40,45	5/8" x 16"	1/4"	8'	72"	1 1/8" diameter	2" dia. O.D.	+12"-12"
EHP7835,40,45	5/8" x 16"	1/4"	8'	83"	1 1/8" diameter	2" dia. O.D.	+12"-12"
EHP61025,30/EHP71025,30	1/2" x 16"	1/4"	10'	72"/83"	1" diameter	1 5/8" dia. O.D.	+16"-16"
EHP61035,40,45	5/8" x 16"	1/4"	10'	72"	1 1/8" diameter	2" dia. O.D.	+16"-16"
EHP71035,40,45	5/8" x 16"	1/4"	10'	83"	1 1/8" diameter	2" dia. O.D.	+16"-16"

INSERT SPECIFIC JOB REQUIREMENTS FROM CHART

--	--	--	--	--	--	--	--

STANDARD CAPACITY

A.N.S.I. CAPACITY

--	--

*Lip and deck, 55,000 lb. minimum yield steel; 2 year structural warranty.

**Models with deck width of 78" (6 1/2') are available upon request.

STANDARD FEATURES

- (2) Bumpers
- Lip 16"
- Grease Fittings
- Working Range Toe Guards
- Maintenance Strut
- Lip Keepers/Night Locks
- Fully Hydraulic Actuation
- Deck Support, Structural "C" Channel
- In-line Safety Stop (prevents free-fall)
- Yellow & Black Diagonal Safety Stripe on Toe Guards
- Motor--1 hp. 1 ph. 60Hz
 - 115 Volt

OPTIONAL FEATURES

- Lip 18"
- Lip 20"
- Weather Seals
- Foam Insulation
- Abrasive Deck
- Explosion Proof
- Emergency Stop
- Three Wheel Fork Lift
- 1 Phase Motor
- 208 Volt
- 230 Volt
- 3 Phase Motor
- 208 Volt
- 230 Volt
- 460 Volt
- 575 Volt
- Laminated Bumper
- Full Range Toe Guards (Powder Coat Yellow)

Rotary Products Inc.

202 East High St. PO Box 370 Ashley Ohio, 43003
Phone #: 1-800-457-5251 Fax #: 740-747-2188



JOB

"EHP" Series Hydraulic Leveler Pit Detail

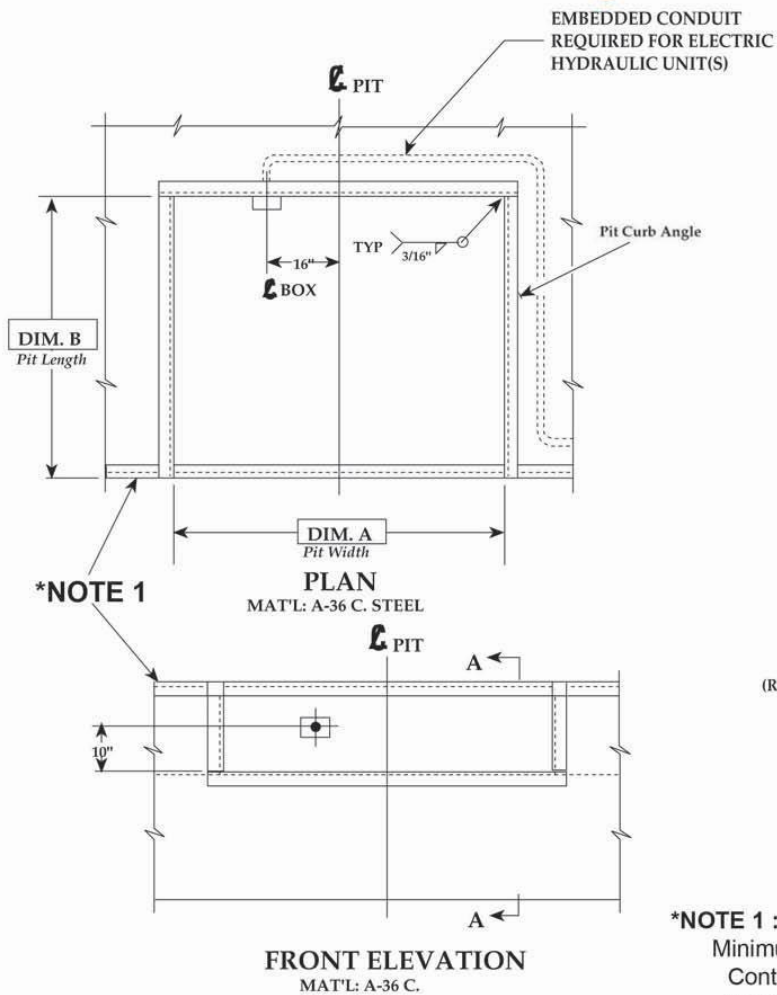

VARIABLE DIMENSIONS				
MODEL	"A"	"B"	"C"	"D"
6'W x 6'L	74"	63"	19 1/2"	20"
6'W x 8'L	74"	87"	19 1/2"	20"
6'-6"W x 6'L	80"	63"	19 1/2"	20"
6'-6"W x 8'L	80"	87"	19 1/2"	20"
7'W x 6'L	85"	63"	19 1/2"	20"
7'W x 8'L	85"	87"	19 1/2"	20"
6'W x 10'L	74"	111"	23 1/2"	24"
6'-6"W x 10'L	80"	111"	23 1/2"	24"
7'W x 10'L	85"	111"	23 1/2"	24"

INSERT SPECIFIC JOB DIMENSIONS FROM CHART

--	--	--	--	--

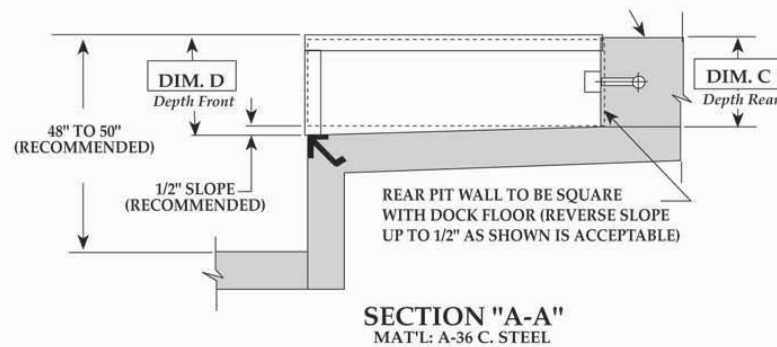

***NOTE 1 :** Angle 3"x3"x1/4"x20"
Minimum Length or Run
Continuous Pit to Pit.
(Supplied By Others)

DRAWN	SCALE: AS	DATE:	DRAWING
:	NOTED	1/30/95	NUMBER:

TOLERANCES		
Inch Dimension	Decimal Dimension	Angles
=	=	= ° 1

Rotary Products Inc.

202 East High St. PO Box 370 Ashley Ohio, 43003
Phone #: 1-800-457-5251 Fax #: 740-747-2188



JOB